

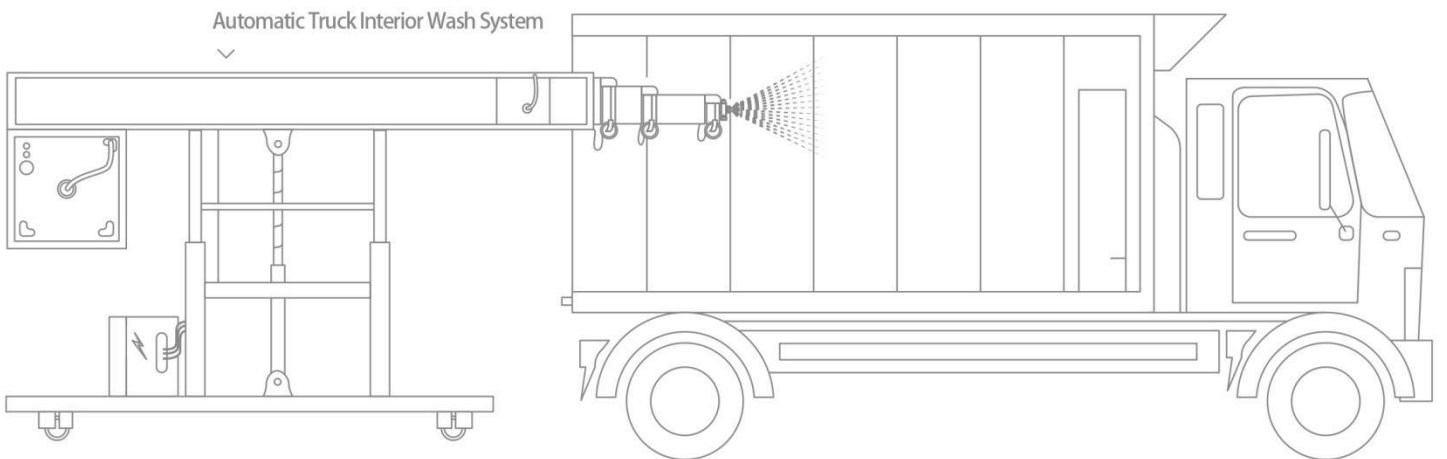

A SENIOR ENTERPRISE
IN THE CLEANING INDUSTRY

MAIN-LINK

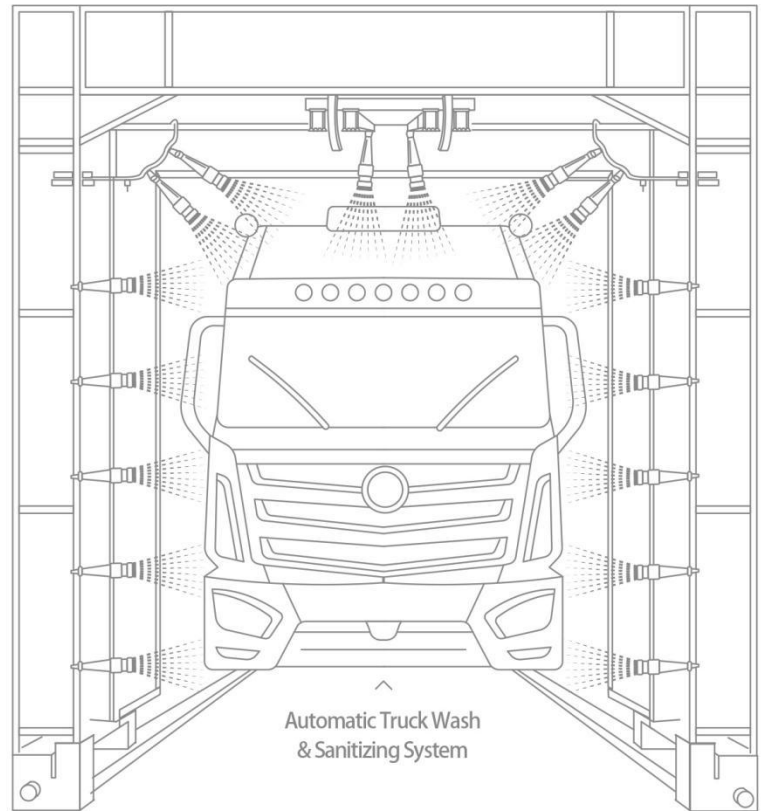

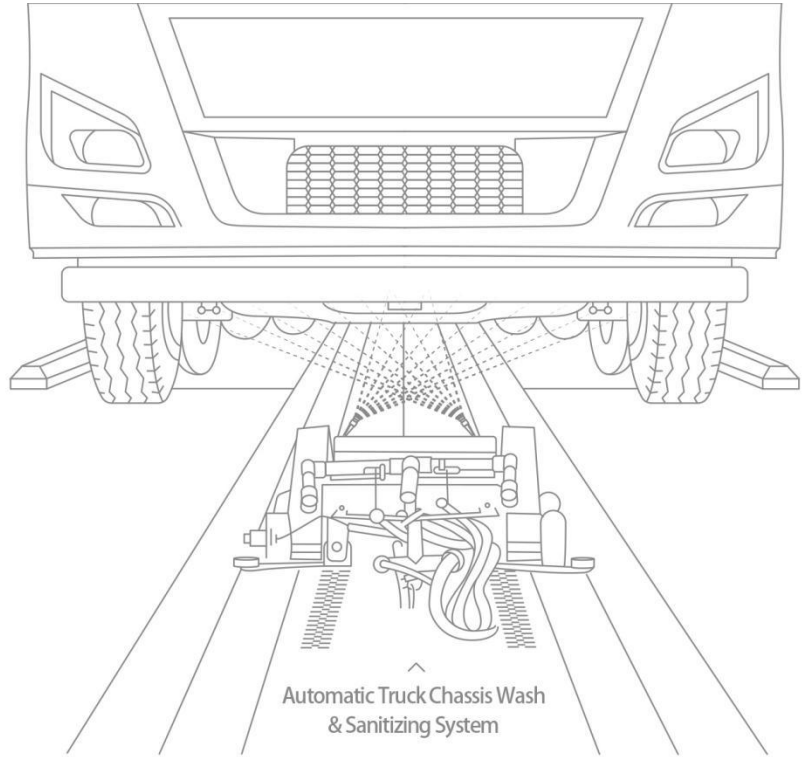

About Us

Qingdao Main-Link Cleaning Equipment Co., Ltd. is a professional equipment manufacturer, dedicated to R & D, Production, Sales and Service. According to the farm and food factory's environment, and combined with the advanced cleaning technology, we explore many kinds of products, including Centralized High Pressure Cleaning System, Automatic Truck Wash & Sanitizing System, Automatic Truck Interior Wash System, Automatic Truck Chassis Wash & Sanitizing System, Centralized Foam Wash & Sanitizing System, polyester Slurry Tankers, Hose Fertilizer Equipment, Solid-liquid Separator, Submersible Agitator, Submersible Cutting Pump, etc. And we pass 3A credit enterprise certification, CE certification, Integration of Informatization and Industrialization certification, ISO9001 quality management system certification, ISO14001 environmental management system certification and iso45001 occupational health and safety management system certification, also we are a high-tech enterprises, SRDI enterprises, the governing unit of ICAC, the governing unit of CAAA-CLEA.

Since 2008, we began cooperation with the SUTTNER (the leader in cleaning industry in German). We shared the technology and production experience. The core parts use the famous branded parts from Interpump, ABB and Siemens, according to national standards. Depending on the advantage of the safe and reliable quality, reasonable design, complete varieties, intelligent and high effective feature, Main-Link get good reputation in cleaning business filed.

In line with "create most value for customer", Qingdao Main-Link Cleaning has established business relationship with many famous companies in China, including CP Group, Shuanghui Group, Muyuan Group, New Hope Group, Wen's Foodstuffs Group, Zhengbang Group, Twins Group, Yuexiu Group, Gongs Group, Haid Group, West Hope Group, Daxiang Group, GSI, Jiahe Agricultural Stockbreedin and Yangxiang Stock, Experiencing years of development, we grow up to a key leading enterprise in cleaning field.

青岛美联清洗设备有限公司
Qingdao Main-Link Cleaning Equipment Co., Ltd.

Centralized Foam Wash & Sanitizing System

You Tube
Video









Data Sheet

Voltage	380V	Air Pressure	6-10bar
Pump Station Power	15kW-45kW	Sub-station Power	3kW-15kW
Pump Station Flow Rate	10-60m ³ /h	Sub-station Flow Rate	20L/min



Advantage

 <p>1、 Can wash various workshop, can be customized as required.</p>	 <p>2、 High Pressure Washing, Foam, Disinfection swift, Premixed and terminal mixed modes.</p>	 <p>3、 Realize multi-pipe washing at the same time, improve working efficiency.</p>
 <p>4、 When hot water supplied, can realize hot water washing for futher disinfection.</p>	 <p>5、 Main material use food grade material, sage and strong.</p>	 <p>6、 Core parts are all mainstream brands.</p>

GRUNDFOS

High Pressure
Piston Pump

SIEMENS

High-efficiency
Inverter Motor

 **DOSATRON**
An Ingersoll Rand Business

Chemical Injector

ABB

SIEMENS

High performance
heavy duty converter

Schneider
Electric

**Core
Part**

SIEMENS

Microcomputer
Control System

Schneider
Electric

Leakage Protection
Type Low Voltage
Circuit Breaker

Schneider
Electric

Pressure Transmitter

Danfoss

SIEMENS

True Color
10-inch Touch
Screen



Some Customer Presentations (In No Particular Order)

Cooperative Customers

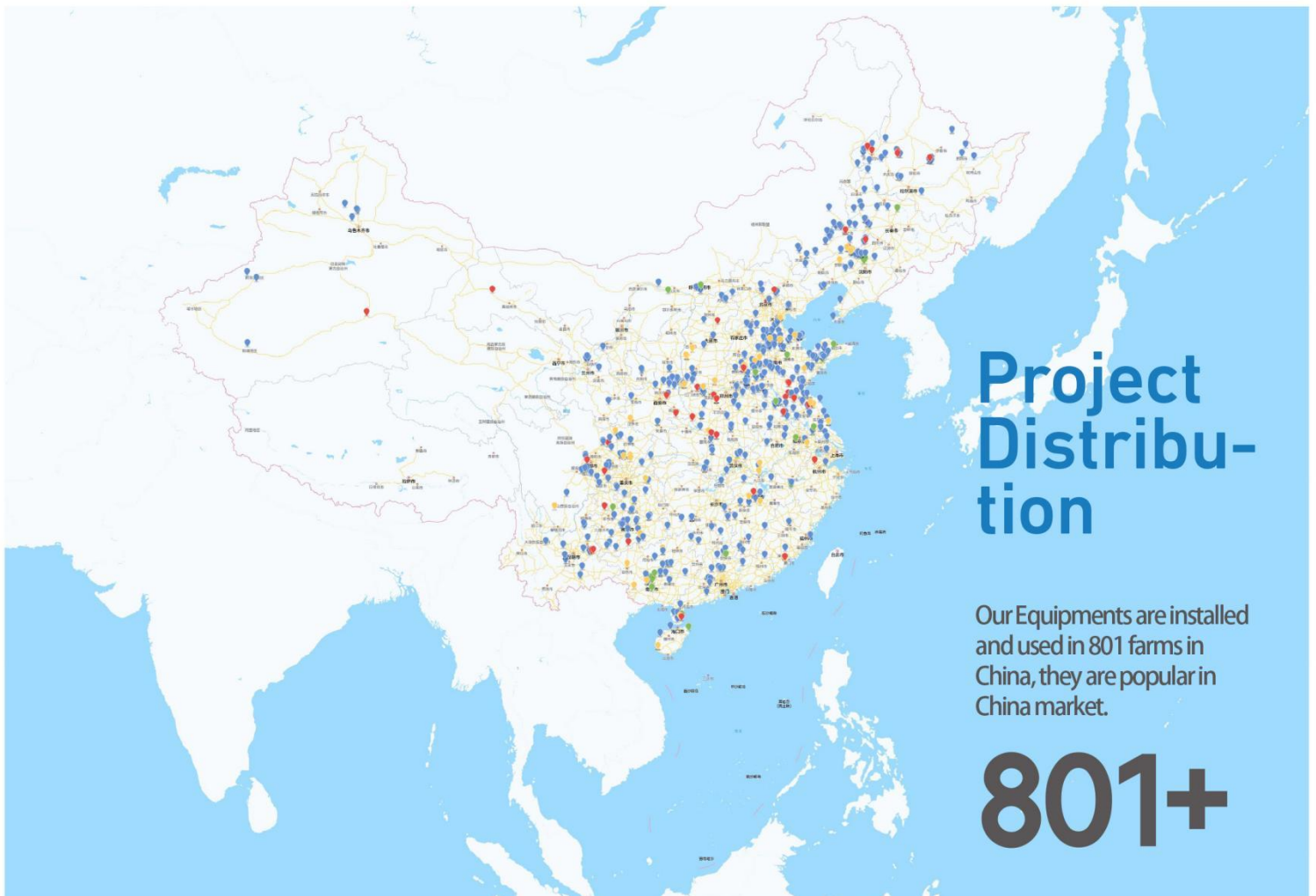

Project Distribution

Our Equipments are installed and used in 801 farms in China, they are popular in China market.

801+

MAIN-LINK



MAIN-LINK
English Website
QR Code

📄 Qingdao Main-Link Cleaning Equipment Co., Ltd.

📍 Address: Taoyuanhe Second Road#166, Jimo, Qingdao, Shandong

☎ Hotline: 400 662 5599 📞 Tel: +86 532-8906 1860

✉ E-mail: info@main-link.com.cn

🌐 Website: www.main-link.cn